



# MotoWinch Operating instructions

## Content

About this manual	1
1. Brief Description	1
2. Technical Specifications	1
3. Safety	1
4. Components and application	1
5. First use as MotoWinch	2
6. Maintenance	4



### About this manual

When text follows a marker (as shown on the left), this means that an important warning indicates that there is a danger of injury to the user or damage to the device or the motorbike.

**Note;** the user is responsible for adequate and personal protection while using the MotoWinch at all times.

### 1. Brief Description and disclaimer;

The MotoWinch shall only be used as described in these operating instructions. The MotoWinch is not suitable for general lifting purposes or for applications other than those described in the operating instructions. Using the MotoWinch implies the supplier's indemnification for damage caused by incorrect or improper use. It is essential that user practices the use of the MotoWinch in a safe and controlled environment. A remote area is definitely not the place where you want first test and try the MotoWinch. The MotoWinch is a great tool but please note that for safety reasons it is advised to never visit rough and remote areas alone on your motorcycle. Supplier will not accept any responsibility for damages caused to motorbike or tools or any kind of bodily harm or death of user due to incorrect use of the Eastbound MotoWinch.

### 2. Technical Specifications

Article nr.	1707001
Length	112cm
Gross weight	1885 gram / 2285 gram

### 3. Safety



**Avoid to come into contact with moving parts during use. Serious injury may occur. Make sure that the strap is always rolled evenly. An unevenly rolled strap can cause blocking or damage of strap and ratchet. Always use the rubber anti-slip foot on hard surfaces. If the surface is slippery, e.g. due to oil leakage, moss or algae growth, there is a substantial risk that the rubber foot does not provide sufficient stability. It is up to the user to make a safe assessment of the situation. However, during the winching, the user must always take position such that, in case of sudden sideways slippage or failure of the winch, the motorbike cannot fall against or on the user.**

### 4. Components and application

Explanation of the parts;

#### The Ratchet;

The ratchet is a standard 3 ton or 5 ton (optional) cargo ratchet. The ratchet lever is of such size that the power required for the various applications is limited. The ratchet must be clean when used and inspected for possible damage. The ratchet has been pre-mounted to the MotoWinch tube with a pipe locking pin.





**The strap:**

The strap is a standard 2 ton 200cm strap for use with the MotoWinch. The strap must be at all times undamaged for use in the MotoWinch. After use, the strap should be cleaned from sand, dirt and grease. If the strap is badly frayed, torn or when the stitching is broken, it should be replaced. In case of doubt please contact Eastbound. **Using a damaged strap is entirely at users own risk.**



The remaining MotoWinch parts and order of assembly:

1. Pulley
2. Shaft male/female 20mm
3. Shaft female/female 20mm
4. Coupling 20 x 14mm
5. Ratchet connection tube 25mm
6. Coupling 20 x 20 mm
7. Tube 25mm
8. Coupling 20 x 20 mm
9. Tube 25mm with anti-slip foot

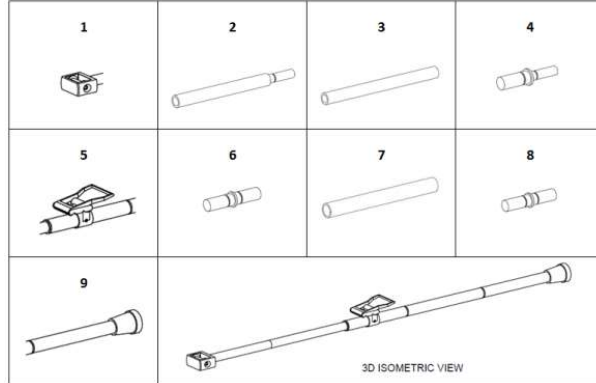

In addition to above the following is included:

- a) Teflon footplate for soft surface (optional)
- b) Storage bag with brake locking strap .
- c) Zip lock bag with spare O-rings

**5. First use of MotoWinch**

**NOTE: It is strongly recommended to try the MotoWinch first under controlled conditions before using under actual conditions in the field. See also Par. 5.2.8 concerning the length of the strap.**

**5.1 General instructions on operation of the ratchet;**

Locking the strap in the ratchet;

1. Pull strap ca. 5 cm through the spindle of the closed ratchet (pic. 1, 2 en 3)
2. Start ratcheting by moving lever up and down (pic.4)

Releasing tension of strap;

1. To release tension, pull locking plate towards the lever (pic. 6)
2. Open ratchet lever until it is completely opened and flat (pic. 7)
3. Now pull the strap to unwind the spindle. If required with a few firm pulls (pic. 8)
4. Pull the locking plate open and close the ratchet. (pic. 9)
- 5.

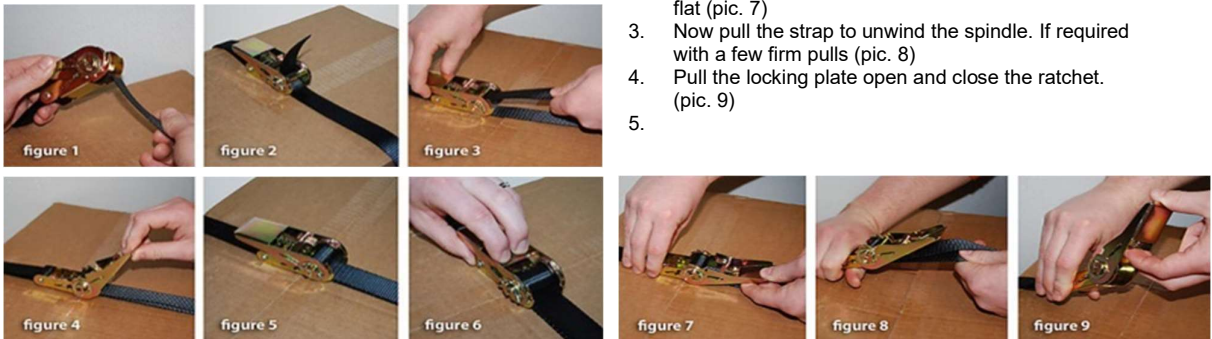

**5.2 Use of MotoWinch;**

1. Check if all parts are present and undamaged.
2. Assemble the MotoWinch Parts 1 through 9 as shown below. **Pay attention that part 5 is orientated correctly, with spindle on top and lever at bottom.** On very soft or marshy surfaces, you also use the Teflon foot plate (optional) for load spreading.



**NOTE; Mounting the ratchet (item 5) upside down will cause failure of the MotoWinch which can result in damage to the motorcycle and bodily harm to the user.**

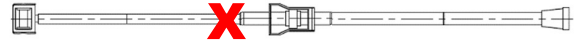
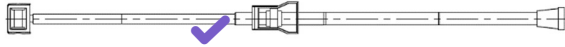

1. Make sure the front of the front wheel is directed downwards by pulling the bottom end of the handle bars of the dropped motorcycle toward the tank.
2. Take the strap and wrap the loop around the lower handle of the motorcycle and pull the opposite free end through the loop into a slipknot. Slide the slipknot as tight as possible. If the handle bars are fitted with metal hand guards, the strap can be attached at the junction between handle bar and hand guard. If the motorcycle does not have metal hand guards, the loop must be tightened on the vibration damper. Take care that the strap is not tightened directly on the throttle tube (in case the bike is on its right side) because this may cause damage to the throttle mechanism.
3. Place the MotoWinch outside the handle bars as close as possible to the strap attachment point with the ratchet handle facing away from the bike. Use the Velcro strap on the storage bag to lock the front brake to prevent the front end from rolling away while winching.
4. Make sure the pulley and ratchet are aligned as shown below. Take the loose end of the strap and guide it through the pulley .
5. Feed the strap into the ratchet spindle and ratchet a number of times until the straps catches on the spindle. Tighten the strap. The ideal situation is that the strap **sticks only about 5 centimeters (2 inches) through the spindle** and "catches" with the first full turn.

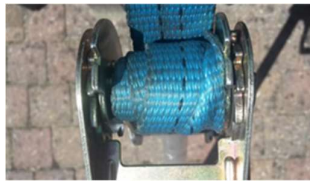

**IMPORTANT: If the strap is too long (LC1500 only)** *If the strap is too long and the strap has to be wound several times on the spindle to tension the strap, it will be at the expense of available winching height, required ratcheting force, the motorcycle cannot be elevated high enough and the strap may run against and open the spindle locking mechanism which causes the strap to unravel and the bike will fall back to the ground. Cut the strap to suit the motorbike (see above)*

**If the strap is too short:**

In principle, the strap cannot be too short. If the strap is accidentally shortened too much or you have a new bike which requires a longer strap, please contact the supplier.

**Note;** Make sure that if the bike is on its right side that you put out the kick stand before you start winching. If the bike is on its left side, be careful with the final step as described under point 9 as not to flip the bike too far and drop it on its right side. While you do the last bit of the lifting by hand, kick out the side stand as soon as you can reach it.

See also the demonstration videos on [www.eastbound.shop](http://www.eastbound.shop)



**Note that not all types off handlebars are suitable to lift the bike. Older model bikes with long steel tubular handlebars like the picture shown, are not strong enough to be used for lifting. In case of doubt, please contact supplier.**



6. The MotoWinch is now ready for use. Start winching;
  - a) Hold the MotoWinch just below the pulley. This will improve guidance of the strap and the balance of the MotoWinch.
  - b) By pulling up the ratchet, the strap will roll on the spindle and the bike will move.
  - c) Put your foot against the rubber foot of the MotoWinch to stabilize it and as an extra precaution against slippage of the rubber foot.
  - d) The MotoWinch will tilt towards the bike, the higher the bike is lifted. This is normal. Under normal circumstance, the rubber anti-slip foot will prevent the MotoWinch from slipping away. (See Note 1)
  - e) Winch slowly, see if the foot is stable and the bike can come up freely and does not roll away at the front or back.



f) Make sure that the strap rolls evenly on the spindle and does not roll up against the side. If it does roll up against the side, the winching will become very difficult and eventually impossible. Stop immediately and start over. (see point 7 above)

**TIP:** while winching, the position of the strap on the ratchet spindle can be manipulated, to prevent uneven roll-up on the spindle, by twisting the top guide roller or by tilting the entire MotoWinch to the left or right.



**Be very careful with unlocking the ratchet! The motorbike will fall back to the ground.**

g) When the winching gets harder (when spindle collects more strap), limit the ratchet action to 1 click at a time.



**Never use an extension lever to operate the ratchet lever. This is dangerous and can cause damage to the MotoWinch and harm to the user.**

h) Pay attention to when the strap reaches the end of its range.

i) When the strap has reached the end of its range, but often before, the bike has reached an angle at which it will be easy to put the bike up straight by hand.

j) Lift the bike by hand for the final push to get it back on its wheels.

k) Engage the side stand as soon as possible (see point 8 above) and let the bike rest on it.

7. Remove the MotoWinch. Inspect the loose parts for any damage and dirt. Clean the MotoWinch components before storing them. In case of damage (except for minor scratching of the metallic surfaces), contact the supplier.



**Note 1;** the underground under the rubber foot must be solid and free from loose gravel, oily substances and any other influences which will adversely affect the grip of the rubber foot on the ground. This is entirely the responsibility of the user. When the underground is very soft, muddy or marshy, use the (optional) load spreader foot plate to spread the load. **Always put your boot/foot against the MotoWinch base to stabilize it and prevent it from slipping away.**

**REMARK:** On some motorbikes the handlebars are mounted in rubbers in the tri-plate. After putting the bike back on its wheels, it can be that the handle bars are slightly skewed. This is not a problem and the handle bars/rubbers can easily be straightened again by putting the front wheel against a solid object like a wall or a pole or by turning the handlebars to the maximum steering angle and push or tap it back to the wright position.

## 6. Maintenance.

After use, remove the sand and mud of all parts. Regularly check the O-rings of the couplings. Although they are not essential to the safe operation of the MotoWinch, these are important for the convenient use of the winch. Grease the O-rings occasionally sparsely with acid-free petrolatum, chain grease/oil or normal bearing grease. Wipe excess grease off. When the O-ring are completely dry, assembly and disassembly of the coupling will be difficult. Regularly check the strap. When the strap is damaged (except for mild fraying of the edges) or torn, it must be replaced. If the stitching of the loop is damaged, the strap must be replaced. Regularly check that all bolts and nuts tight. Carefully clean all parts and replace damaged parts with new ones.

- Replacement O-rings;
- 20mm connections; 15,60mm x 1,78mm. NBR or equivalent
- 14mm connections; 9,25mm x 1,78mm. NBR or equivalent

PDF User Instructions Download



YouTube Demo Video



[www.eastbound.shop](http://www.eastbound.shop)  
[info@eastbound.shop](mailto:info@eastbound.shop)

Nothing in this publication may be reproduced and / or made public by print, photocopy, microfilm or any other means without the prior written permission of the publisher. Technical data may be changed without prior notice. Eastbound is not responsible / liable for damage / personal injury due to (incorrect) use of this product. Eastbound is interested in your comments and about this products and manual